



# LOMANCO

## Tile Roof Installation Instructions BIB & BEB Whirlybird



1. After placement of underlayment and layout of battens, use the opposite side of this page to determine the proper spacing of the turbines. Locate base opening between rafters and between the second and third batten or approximately 24" from the ridge and mark hole to be cut in decking. The hole should be 12" in diameter. When placing hole remember to allow for batten width at marked line. Place close to the upper batten. Cut each hole as marked.

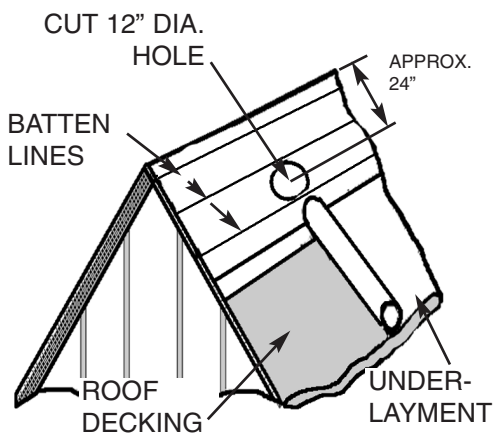

2. Level turbine by rotating top half clockwise. Top of turbine should be level both parallel and perpendicular to the ridge.

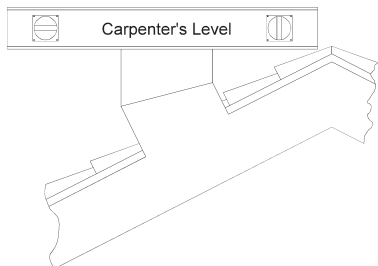

Cut a slit in the underlayment approximately 8" from each side of the 12" hole out from center of the hole parallel to the ridge. Prime the underside of the turbine base with approved roofing cement. Slide the upper half of the base under the underlayment and let the lower half set on the top of the underlayment.

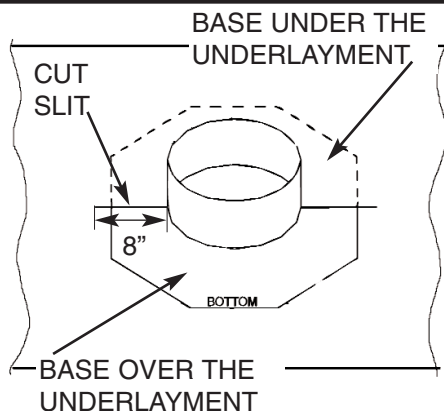

Nail in place every 4" to 6" along the perimeter of the eight-sided base. Cover each nail head with roofing cement.

3. Install the battens on the roof according to previous layout lines. Install tile. Cut tile around the turbines leaving approximately a 1" gap around the perimeter of the elbow to allow for mortar placement.

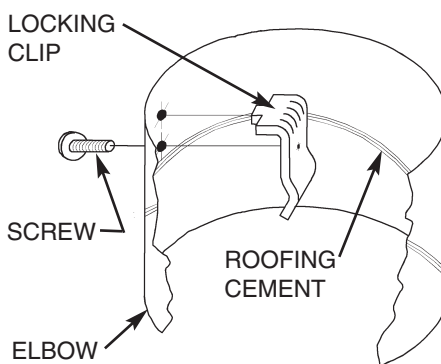

4. Place locking clamp across seam and tighten as shown with screw provided. Seal all inside seams with approved roofing cement.

5. Position Whirlybird® on elbow. Line up predrilled holes in the brackets and base and fasten with sheet metal screws provided.

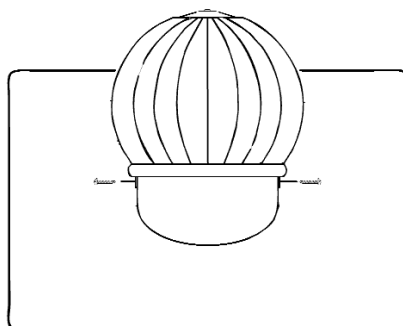

6. After installation, check to see that the Whirlybird® turns freely. During transportation it may have been shifted slightly. If necessary, minor adjustments may be made by gently prying lowest point of the turbine upward to remove any wobble.

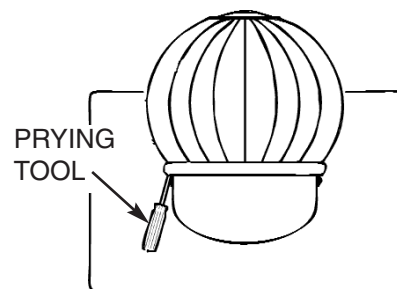

7. Mix enough mortar to fill in the 1" gap between the turbine elbow and roofing tile. Place mortar between the tile and elbow to create a water resistant barrier. Make sure mortar does not create a pool of water on the upper side or sides of the turbine elbow. After mortar is dry, turbine and mortar can be painted to match tile if so desired.

Lomanco, Inc., guarantees this product against defects due to workmanship, parts, or mechanical failure forever. For replacement of the defective product send it, freight prepaid, to Lomanco, Inc., 2101 West Main Street, Jacksonville, AR 72076. If the unit is defective, it will be replaced with a new unit at no charge and returned, freight prepaid. Guarantee does not include replacement due to destructive storms. Guarantee is transferable from the original owner to subsequent owners. **GUARANTEE APPLIES TO RESIDENTIAL USE ONLY.** **GUARANTEE IS VOID IF USED ON FIREPLACE, CHIMNEY, OR STOVEPIPE.**

**Lomanco, Inc.**  
**P.O. Box 519 2101 West Main**  
**Jacksonville, AR 72076**  
**800-643-5596**  
**e-mail: [info@lomanco.com](mailto:info@lomanco.com)**  
**Internet: [www.lomanco.com](http://www.lomanco.com)**